

Knife gate valve SLF

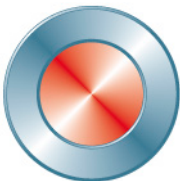
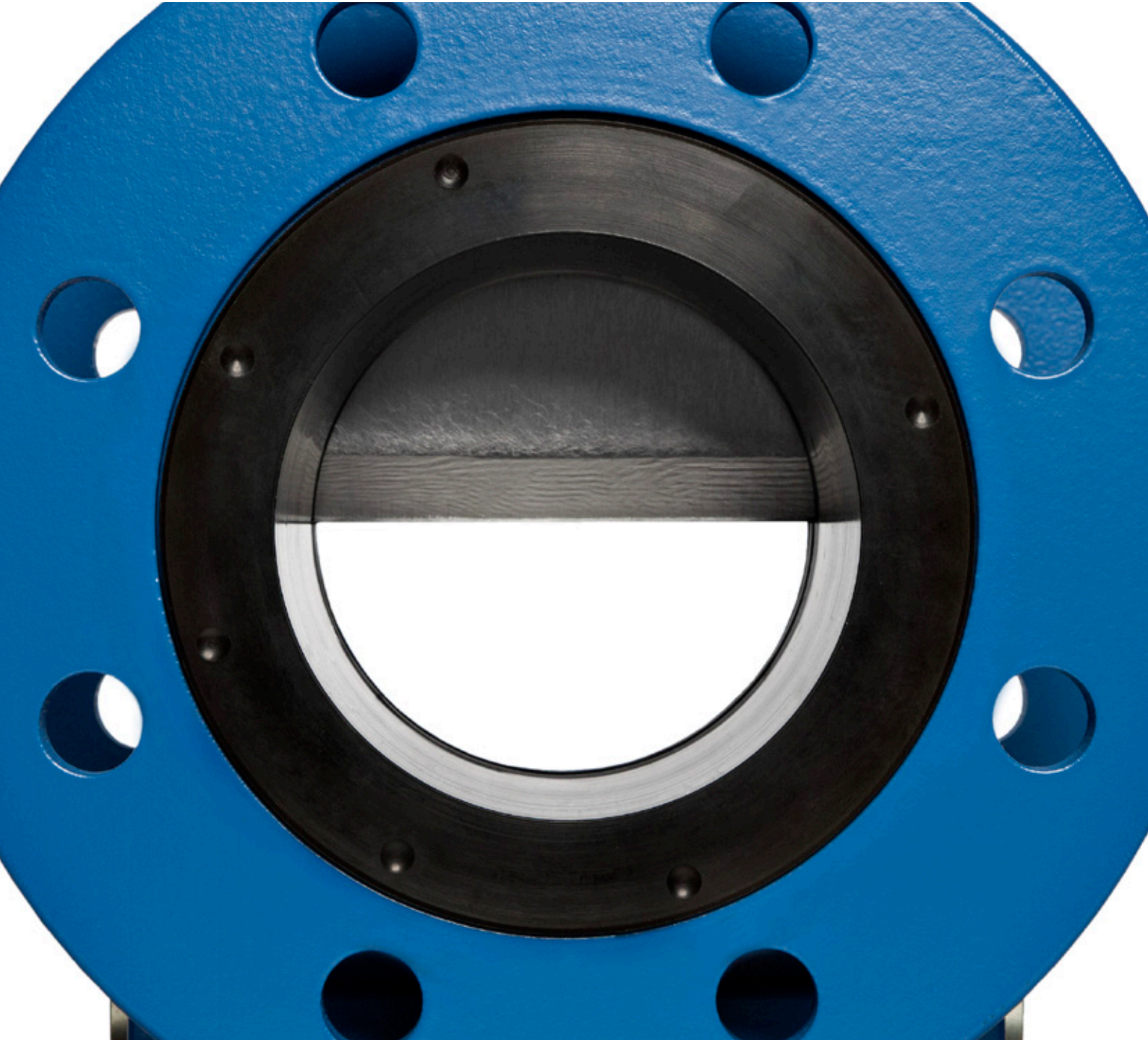

Stafsjö

SINCE 1666

avror-arm.ru
+7 (495) 956-62-18

Data is only for informational purpose. All specifications are subject to change without notice.

Knife gate valve SLF

Stafsjö's knife gate valve SLF is a flanged full bore valve for the most abrasive and demanding slurry where operation reliability and low life cycle cost are emphasized. The SLF is especially suitable on old non-centred pipes or low pressure applications. Thanks to its flanged design it is also easy to remove if it needs to be replaced or maintained.

When the valve is in the open position, the seats form a tight extension of the pipe line and no metal parts are in contact with the media. When the valve closes the two seats are displaced axially forming a seal with the gate until it forms a complete closure – 100% tight in any pressure direction.

The SLF comes with a coated flanged valve body in nodular iron with integrated purge ports in the lower end to be utilized if a bottom cover is assembled on the valve. The unique seats are available in low friction special EPDM, natural rubber or Viton. These seal against a gate in duplex stainless steel specially machined and grinded to reduce the friction when the valve is operated. It can also be supplied hard chromed to give a really hard and wear resistant surface. The gland box system is as standard supplied with three layers of our TwinPack™ and a box bottom scraper in order to give a first-rate sealing and a straight gate guidance.

The top works is modular designed and there are several actuator types and accessories to choose from in our standard collection – all easily exchangeable between each other. For security reasons the valve is always supplied ready to be locked in either open or closed position.

The SLF valve is designed, manufactured, inspected and tested according to the European Pressure Equipment Directive (PED 97/23/EC) category I and II module A1. The valve is CE marked when it is applicable.

Other slurry valves are the lugged SLV available up to DN 900 and the high pressure versions SLH and SLX which can be supplied for pressures up to 50 bar.

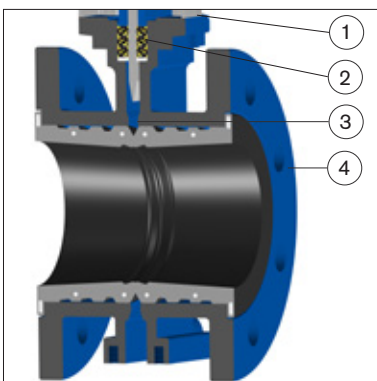

A precise gate guidance extends the service life

A solid top work (1), a robust gland box system (2), internal guiding supports (3) guarantee a precise gate guidance, which is crucial during cycling to minimize the wear on the seats. The extended face-to-face (4) further reduces the stress on the seats.

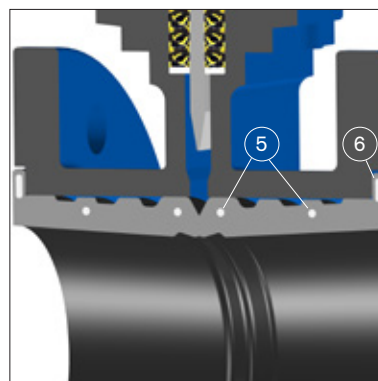

Built in steel reinforcements improve the performance

The front reinforcement rings (5) ensure the seats' shape, position, and strength remain during operation while the flange sealing reinforcements (6) secure a tight and exact position of the seats towards the gate and connecting flanges.

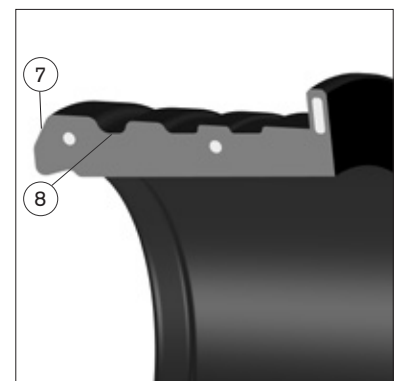

Integrated expansion areas give low operating force and minimize the stress on the seats

The seat entrance area (7) is designed to give a smooth gate entry and the expansion areas (8) allow the seat to be axially flexible, requiring minimal operating force.

Design data

Sizes	Flange drilling	Face-to-face dimension	Corrosion protection
DN 80 - DN 400	EN 1092 PN 10 ASME/ANSI B16.5 Class 150 AS 2129 Table D AS 2129 Table E	Stafsjö manufacturing standard	Non-corrosive resistant materials are coated in colour RAL5015 acc. to Stafsjö's standard, which fulfill the requirements in EN ISO 12944 class C3.

Other sizes, flange drillings and corrosion protection on request.

Leakage rate	Pressure tests
EN 12266-1:2012 rate A: No visually detectable leakage is allowed for duration of the test.	Pressure tests are performed with water at 20° C according to EN 12266-1:2012. Pressure shell test: 1,5 times maximum allowable working pressure for open valve. Pressure seat tightness test: 1,1 times maximum allowable differential pressure for closed valve.

Maximum working pressure body at 20°C		Maximum differential pressure at 20°C	
DN	bar	DN	bar
80 - 400	10	80 - 400	10

Basic equipment

A. Valve Body			
Material	Code	Type	Maximum temperature °C
Nodular iron	(L)	EN-JS1020	200

DN 80-DN 200: 1/2", DN 250-DN 400: 3/4", DN 500-DN 600 Rp 1"

B. Gate			
Material standard	Type	Option	
Duplex stainless steel	EN 1.4462/S32205	Hard chromed surface	

Other materials on request.

C. Seats			
Material	Code	Maximum temperature °C	
EPDM	(E)	120	
Natural rubber	(NR)	80	
Viton	(V)	180	

D. Box packing			
Material	Code		Maximum temperature °C
TwinPack™ with scraper in UHMWPE	(TY)		80

Actuators

Manual	Code	Automatic	Code
Hand wheel ¹⁾	(HWR)	Pneumatic cylinder	(EC)
Bevel gear ²⁾	(BG)	Electric motor ²⁾	(EM)
		Hydraulic cylinder ²⁾	(MH)

¹⁾ Available with rising and non-rising stem. For recommended size, see page 5 column E

²⁾ For recommended size, see separate data sheet

Double-acting pneumatic cylinder			Electric motor (AUMA multi-turn)		
DN valve	Size EC	Force at 5 bar (kN)	DN valve	AUMA type	Attachment
80 - 150	EC 160	9,0	80	SA 07.2	F10/A
200 - 250	EC 200	14,1	100 - 125	SA 07.6	F10/A
300 - 350	EC 250	22,1	150 - 350	SA 10.2	F10/A
400	EC 320	36,2	400	SA 14.2	F14/A

The table above gives recommended cylinder sizes at normal operation with 5 bar air pressure. For other operating conditions, please contact Stafsjö or your local representative for advice.

Electric motors are mounted according to standard ISO 5210. The table above gives recommended motor sizes at normal operation. For other operating conditions, please contact Stafsjö or your local representative for advice.

The actuators are described in detail in separate data sheets. For actuators classified according to ATEX, please contact Stafsjö or your local representative.

Specify the Stafsjö valve

Stafsjö's valves are modular designed and they can easily be customized according to media and requirements. Below are examples of how you can specify your Stafsjö valve. Further information is available on www.stafsjo.com.

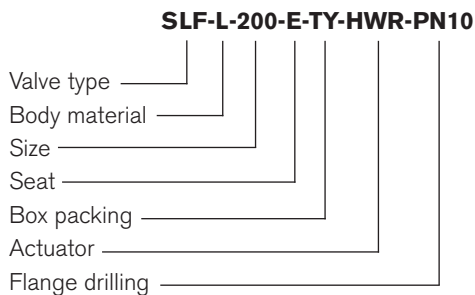

All electronics and basic equipment that differs from standard must be specified in detail.

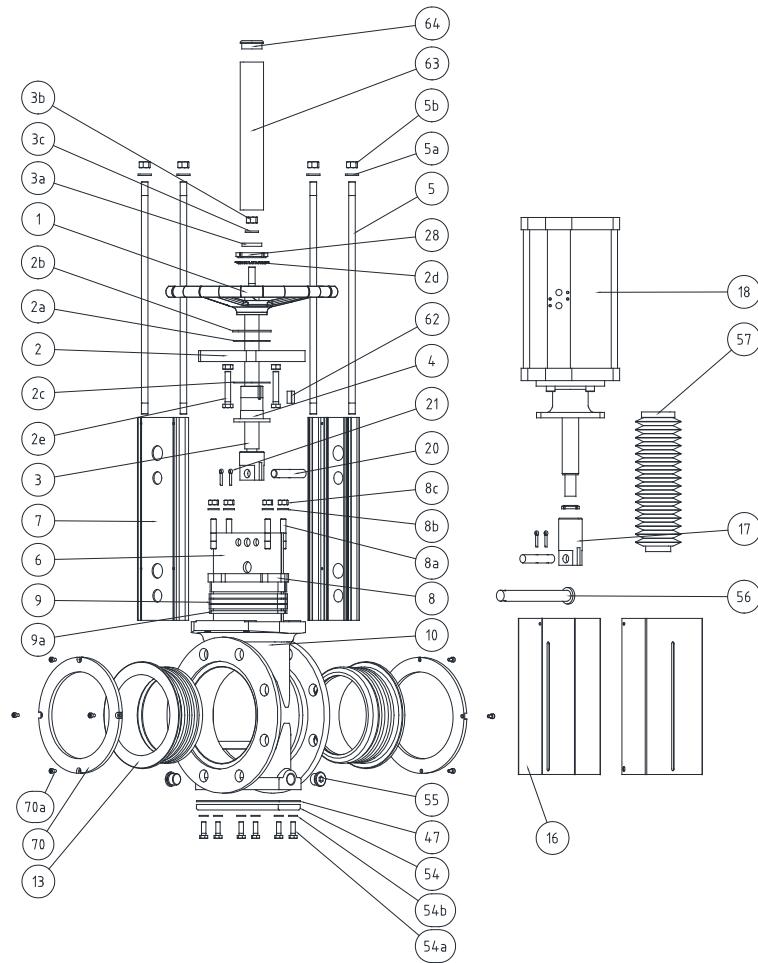

Part list

Pos.	Part	Material (Name)
1	Hand wheel	Coated cast iron Ø 315 (EN-JL1040/GG25), ≥ Ø 400 (EN-JL1030/GG20)
2	Yoke	Coated steel (EN 1.0038)
2a	Bearing	Iglidur XTM
2b	Slide washer	Brass (CW614N)
2c	Bearing	Iglidur XTM
2d	Washer	Stainless steel (EN 1.4305)
2e	Locking nut	Steel, zinc coated
3	Stem	Stainless steel (EN 1.4305) ≥ DN 350: Gate clevis in coated carbon steel (EN 1.0045)
3a	Stop washer	Stainless steel (EN 1.4301)
3b	Screw	Stainless steel (A2)
3c	Washer	Stainless steel (A2)
4	Stem nut	Brass (CW614N)
5	Tie rod	≤ DN 300: Stainless steel (EN 1.4301)
5a ³⁾	Washer	Stainless steel (A2)
5b ³⁾	Nut	Stainless steel (A2)
6	Gate	See equipment B
7	Beam	≤ DN 300: Aluminium (EN AW-6063-T6) ≥ DN 350: Coated steel (EN 1.0038)
8	Gland	Coated nodular iron (EN-JS1050/GGG50)
8a	Stud bolt	Stainless steel (A2), zinc coated

Pos.	Part	Material (Name)
8b	Washer	Stainless steel (A2)
8c	Nut	Stainless steel (A2), zinc coated
9 ²⁾	Box packing	See equipment D
9a ²⁾	Box bottom scraper	UHMWPE
10	Valve body	See equipment A
13	Seat ²⁾	See equipment C
16	Gate guard, not for HW	Carbon steel
17	Gate clevis	Stainless steel (EN 1.4305) ≥ DN 350: Coated carbon steel (EN 1.0045)
18	Cylinder	See data sheet
47 ¹⁾	Gasket	See data sheet for Stafsjö's accessories
54 ¹⁾	Bottom cover	See data sheet for Stafsjö's accessories
54a ¹⁾	Screw	See data sheet for Stafsjö's accessories
54b ¹⁾	Washer	See data sheet for Stafsjö's accessories
55	Plug	Steel, zinc coated
56 ¹⁾	Locking pin	See data sheet for Stafsjö's accessories
57 ¹⁾	Stem protection	See data sheet for Stafsjö's accessories
62	Wedge	Stainless steel
63	Stemtube	Coated stainless steel (EN 1.0038)
64	Plug	Plastic
70 ¹⁾	Load distribution rings	See data sheet for Stafsjö's accessories
70a ¹⁾	Screws	See data sheet for Stafsjö's accessories

¹⁾ Optional accessories

²⁾ Recommended spare parts

³⁾ ≥ DN 350 details are replaced by screws, washers and nuts.

SLF with load distribution rings (LDR) SLF without load distribution rings

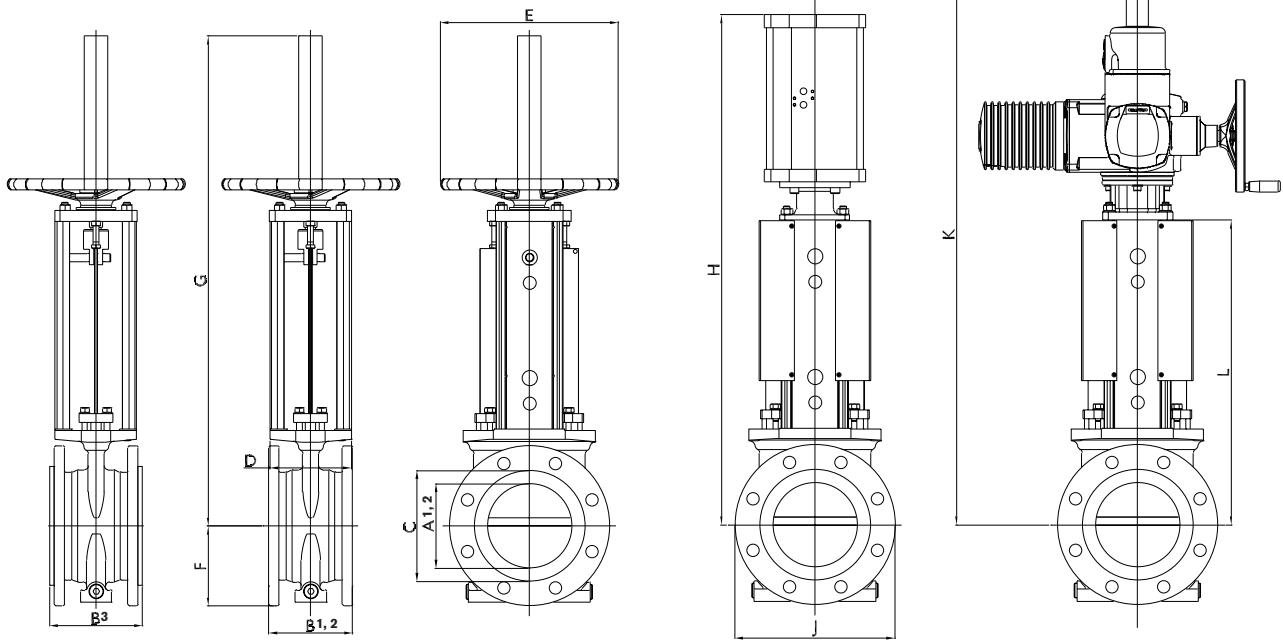

Main dimensions

Dimensions (mm)														
DN	A ¹	A ²	B ¹	B ²	B ³	C	D	E	F	G	H	J	K	L
80	80	75	151	146	158	116	80	315	100	712	749	200	801	419
100	100	93	151	146	162	143	80	315	115	748	809	230	836	454
125	124	120	151	146	162	172	145	315	127	868	938	254	971	533
150	148	145	154	149	165	197	145	315	143	878	948	285	981	543
200	199	190	161	156	172	253	145	315	172	1031	1147	343	1079	641
250	249	240	226	221	241	303	145	400	204	1162	1279	406	1261	723
300	293	283	247	242	262	356	175	520	242	1400	1609	483	1409	861
350	337	327	256	251	271	408	200	520	268	1510	1714	535	1569	916
400	375	365	278	273	293	464	200	635	300	1650	1908	590	1701	998

A¹) Inlet diameter. A²) Bore diameter.

B¹) Minimum required face-to-face for installation without load distribution rings. B²) Installed face-to-face without load distribution rings.

B³) Installed face-to-face with load distribution rings (LDR). When the connecting flanges are rubber lined or when they do not cover dimension C + 10 mm, there is a need to install load distribution rings between the seats and the flanges to avoid functional problems and to ensure the seats will stay in correct position after every valve manoeuvring. If load distribution rings are ordered they are as standard assembled on the valve upon delivery.

Main dimensions are only for information. Contact Stafsjö for certified drawings.

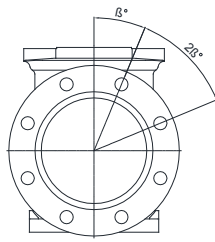

DN 80 - DN 200

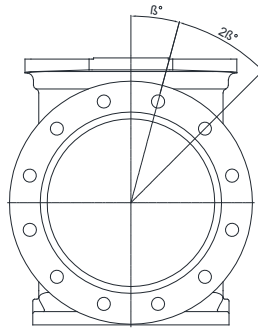

DN 250 - DN 300

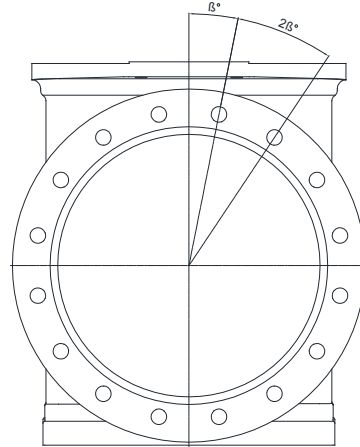

DN 350 - DN 400

Flange drilling according to EN 1092 PN 10

Flange drilling information (mm)									
DN	80	100	125	150	200	250	300	350	400
Outside flange diameter	200	220	250	285	340	395	445	505	565
Bolt circle diameter	160	180	210	240	295	350	400	460	515
Number of throughgoing holes (°)	8	8	8	8	8	12	12	16	16
Size of throughgoing holes	Ø18	Ø18	Ø18	Ø22	Ø22	Ø22	Ø22	Ø22	Ø26
β°	22,5	22,5	22,5	22,5	22,5	15	15	11,25	11,25

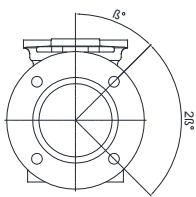

DN 80

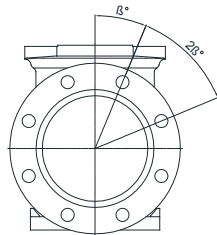

DN 100 - DN 200

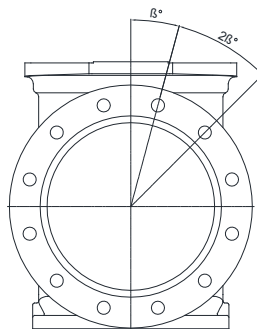

DN 250 - DN 350

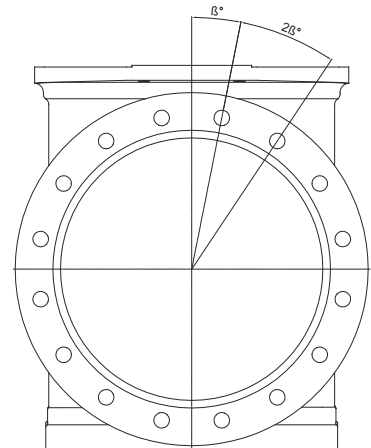

DN 400

Flange drilling according to ASME/ANSI B16.5 Class 150

Flange drilling information (mm)									
DN	80	100	125	150	200	250	300	350	400
Outside flange diameter	190,5	228,6	254	279,4	342,9	406,4	482,6	533,4	596,9
Bolt circle diameter	152,4	190,5	215,9	241,3	298,5	362	431,8	476,3	539,8
Number of throughgoing holes (°)	4	8	8	8	8	12	12	12	16
Size of throughgoing holes	Ø18	Ø18	Ø22	Ø22	Ø22	Ø26	Ø26	Ø30	Ø30
β°	45	22,5	22,5	22,5	22,5	15	15	15	11,25

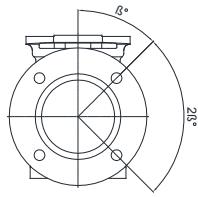

DN 80 - DN 100

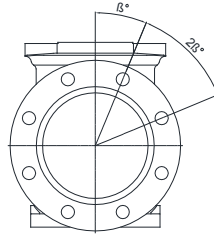

DN 125 - DN 250

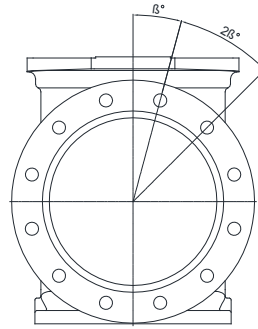

DN 300 - DN 400

Flange drilling according to AS 2129 Table D

Flange drilling information (mm)									
DN	80	100	125	150	200	250	300	350	400
Outside flange diameter	185	215	255	280	335	405	455	525	580
Bolt circle diameter	146	178	210	235	292	356	406	470	521
Number of throughgoing holes (°)	4	4	8	8	8	8	12	12	12
Size of throughgoing holes	Ø18	Ø18	Ø18	Ø18	Ø18	Ø22	Ø22	Ø26	Ø26
β°	45	45	22,5	22,5	22,5	22,5	15	15	15

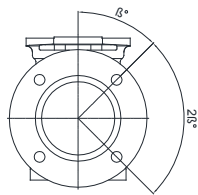

DN 80 - DN 100

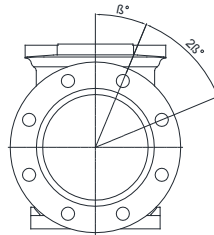

DN 125 - DN 200

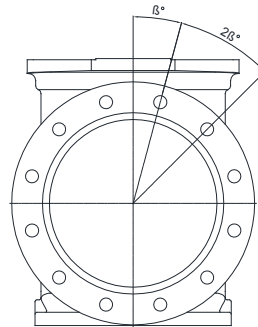

DN 250 - DN 400

Flange drilling according to AS 2129 Table E

Flange drilling information (mm)									
DN	80	100	125	150	200	250	300	350	400
Outside flange diameter	185	215	255	280	335	405	455	525	580
Bolt circle diameter	146	178	210	235	292	356	406	470	521
Number of throughgoing holes (°)	4	8	8	8	8	12	12	12	12
Size of throughgoing holes	Ø18	Ø18	Ø18	Ø22	Ø22	Ø22	Ø26	Ø26	Ø26
β°	45	22,5	22,5	22,5	22,5	15	15	15	15

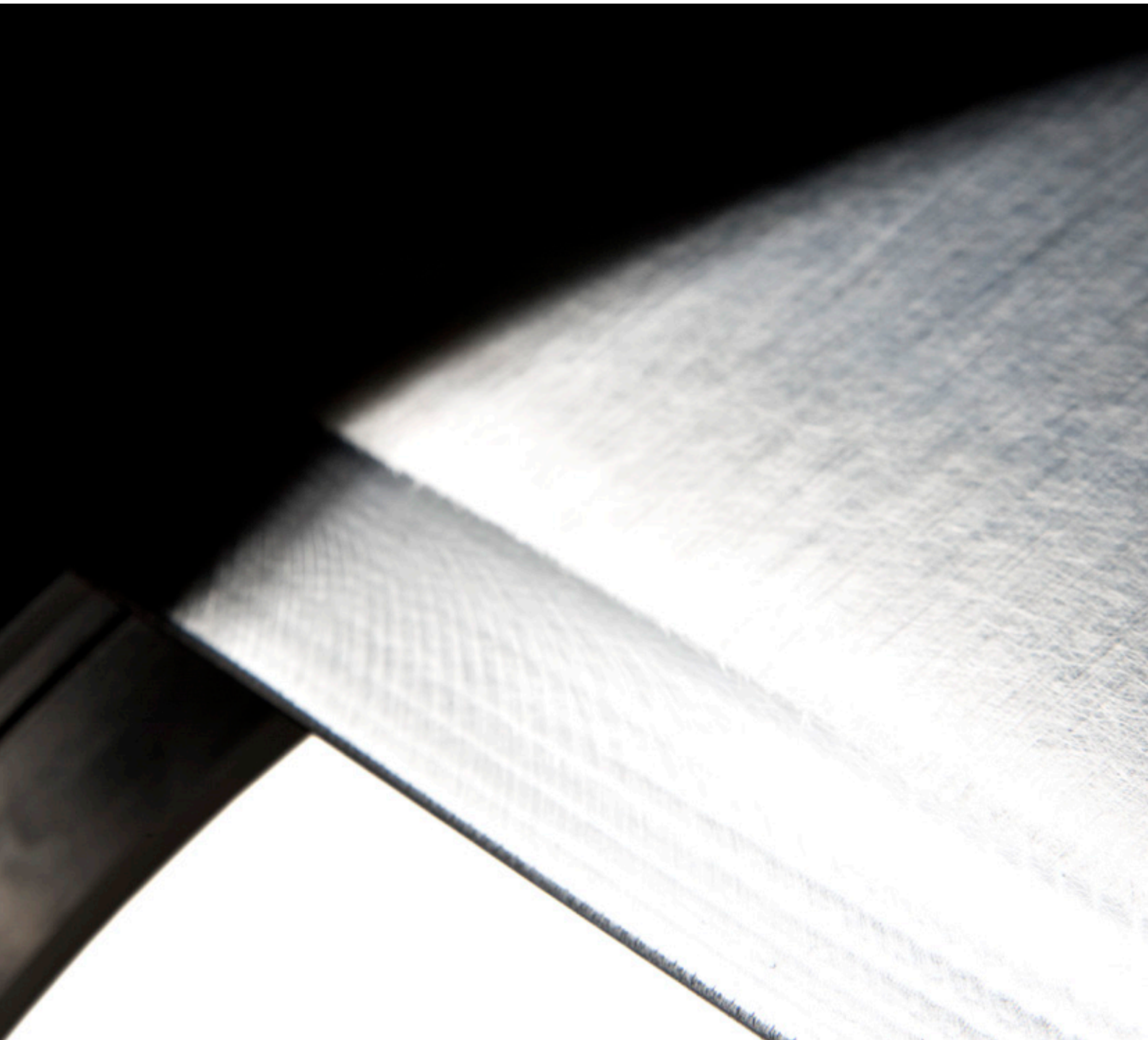

Globally active. Locally represented.

AFRICA South Africa: Valve & Automation (Pty) Ltd, **ASIA** China: EBRO ARMATUREN (BEIJING) CO., LTD, India: Ebro Armaturen India Pvt. Ltd, Indonesia: Contromatic Prima Mandiri PT, Japan: SKC Co. Ltd, Malaysia: Precision Control SdnBnd, Philippines: EBRO ARMATUREN (PHILIPPINES) INC., South Korea: Sherpa Automation, Thailand: EBRO VALVES (Trading) Co. Ltd, Vietnam: EBRO VALVES (Thailand) Co., Ltd, **AUSTRALIA/OCEANIA** Australia: EBRO ARMATUREN Pacific PTY. LTD, New Zealand: H.J.Asmuss&Co.Ltd **EUROPE** Austria: EBRO ARMATUREN GmbH, Belgium: V.C.T. - Valve & Connector Technology n.v., Denmark: Valtor Industri A/S, Finland: Tecalemit Flow Oy, France: EBRO ARMATUREN, Germany: EBRO ARMATUREN Gebr. Bröer GmbH, Great Britain: EBRO Valves Ltd, Hungary: EBRO ARMATUREN Kft, Ireland: ESI Technologies Ltd., Iceland: Hédinn HF, Italy: EBRO VALVOLE SRL, The Netherlands: EBRO VALVES B.V., Norway: BAGGES AS, Poland: EBRO ARMATUREN GmbH, Portugal: AxFlow Comércio de Equipamentos LDA, Russia: LesBumMash Ltd, Roitech and Hawle Sevkom, Spain: EBRO ARMATUREN ESPAÑA, S.L., Switzerland: EBRO Armaturen Est. & Co. KG, Sweden: Stafsjö Valves AB and Ahlsell Sverige AB, Turkey: EBRO ARMATUREN Otomasyon Sistemleri San ve Tic Ltd. Sti, Ukraine: EBRO ARMATUREN GmbH Representative office Kiev **NORTH AMERICA** Canada: Armour Valve Ltd, USA: EBRO ARMATUREN USA Inc. **SOUTH AMERICA** Argentina: ESCO ARGENTINA SA, Brazil: ELAN Equipamentos Industriais LTDA, Chile: Ebro Stafsjö Valves Chile Ltd
For other countries, please contact us directly.

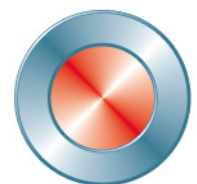

Stafsjö
SINCE 1666

avrora-arm.ru
+7 (495) 956-62-18